

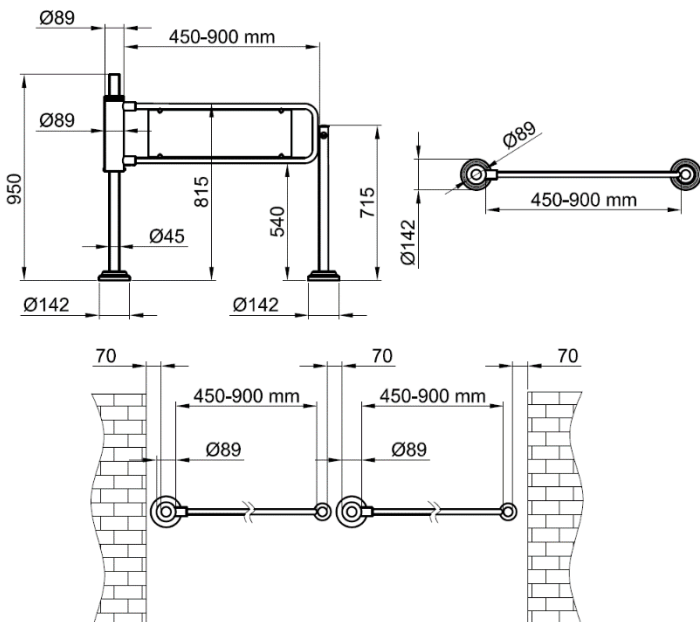

- Power Requirements** : None (standard version) / For electromagnetic lock version: 24v DC. (250 mA)
- Wing Features** : Ø27 x 2 mm wing flap specially bent 304-grade stainless steel.
- Body Features** : Ø89 x 3 mm 304-grade (Opt. 316-grade) stainless steel.
- IP Rating** : IP 67
- System Features** : Manually operated unidirectional, push to open (90° - clockwise or counter clockwise), spring loaded return system. For electromagnetic lock version in case of power failure the electromagnetic lock releases the panel for free passage.

Optional Accessories and Applications:
Electromagnetic Lock with 35 kgf resistance , manual lock, key lock pole, separator.

MANUEL LOCKED



ELECTRO MAGNETIC LOCKED

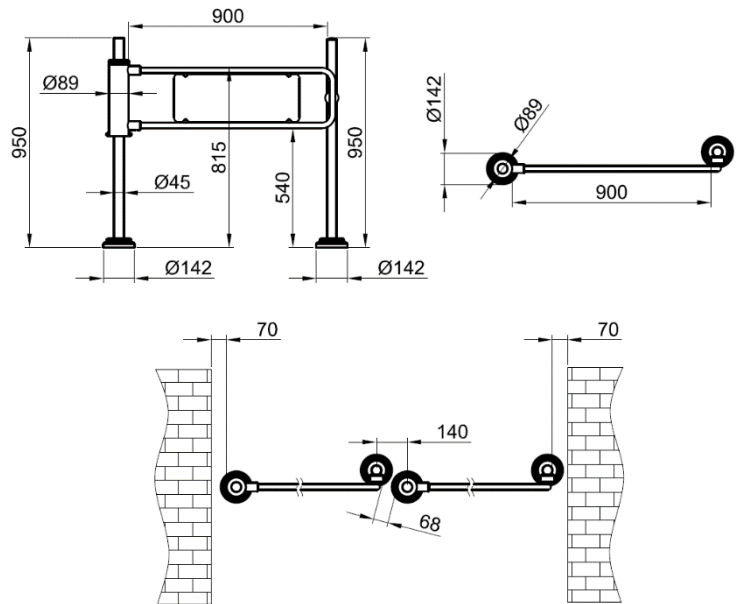

**Design and specifications are subject to change without notice*