



- Power Requirements** : 110/220-240V. 60/50Hz. AC (%±10) 24V.DC
 -At standby ~10W. During operation ~39W. (Single-sided)
 -At standby ~20W. During operation ~78W. (Centre unit)
- Wing Movement** : Electronically controlled rapid wing movement for quick and smooth passages.
- Wing Features** : Soft blue illuminated 12mm impact resistant tempered glass (Opt. polycarbon) wings. A passage lane consists of two single-sided units.
- Top Lid** : 20 mm. thick natural granite (Star Galaxy Black) stone on top is standard feature for a decorative and aesthetical appearance. Different granite patterns and colours are available. (Opt. stainless steel, tempered glass or wood)
- Body Features** : 304-Grade satin finished stainless steel.
 Stainless steel and acrylic plates for both directions are provided with the top lid for covering reader devices. Adequate space is available under these plates for installation of various reader devices and wiring. Acrylic plates are recommended for the integration of RF units
- Indicator & Display Features**
 : On the front panels, DOT MATRIX animated LED status displays of Green Arrow and Red Cross are provided as standard feature.
 In addition, an illuminated acrylic layer under the granite top lid is included. At standby, the acrylic layer illuminated in blue; during authorised passages it flashes green; when an unauthorized attempt is detected or during alert mode it flashes red.
- Operating Temperature, Humidity, IP Rating**
 : -20°C - +68°C / RH 95% non-condensing / IP 44 indoor model
- Control System** : All inputs are opto-coupler protected .Controlled by dry contact or grounding input. Compatible with all access control systems that provide dry contact or grounding outputs. Optional RS232/RS485/TCP IP control module is available.
- System Features& Operation**

:Microprocessor controlled, PWM DC motor driven mechanism; multi sensor IR passage detection system. The wings are closed crossing the lane at standby. Wings open rapidly to allow passage when input is received by either direction. Internal dip switch selectable; free passage by photocell detection, restricted access, controlled access on both or single direction modes are built in features.

Output Data

: The system provides dry contact passage feedback by relays.

Emergency Mode

: The system allows free passage by opening the wings while turning all indicators and wings green upon receiving emergency input from an alarm system. Wings open automatically in case of a power failure in default fail-open mode (powered by internal back-up battery). User can select fail-closed mode by internal dip switch.

Wing Speed

: Wing speed is electronically controlled by adjustable PWM motor drive system.

	Passage Width 550 mm
Wing Height 900 mm	~ 0,8 seconds factory default
Wing Height 1200 mm	~ 1,0 seconds factory default
Wing Height 2000 mm	~ 1,2 seconds factory default

- ❖ The above figures are for standard tempered glass wings.
- ❖ Default speeds can be adjusted by consultation at the time of order

Flow Rate

: Capacity of Mechanism: ~1-120 passages/minute; Nominal: ~25-50 passages-per-minute (Recommended reference figure).
 ❖ Utilisation of different access control units can change the flow rate.

Standard Features

: Dot matrix direction and status indicators, natural granite top lid, stainless steel and acrylic reader cover plates for both directions, luggage trolley passage functionality.

Optional Accessories and Applications

: Tempered glass side (lateral) panels, remote control unit, interface unit for PC, RS 485, RS232 and LAN, counter, audio-messaging system, alarm sensor, bottom plate, coin slot/intelligent coin system and coin box, separator, card reader pole.

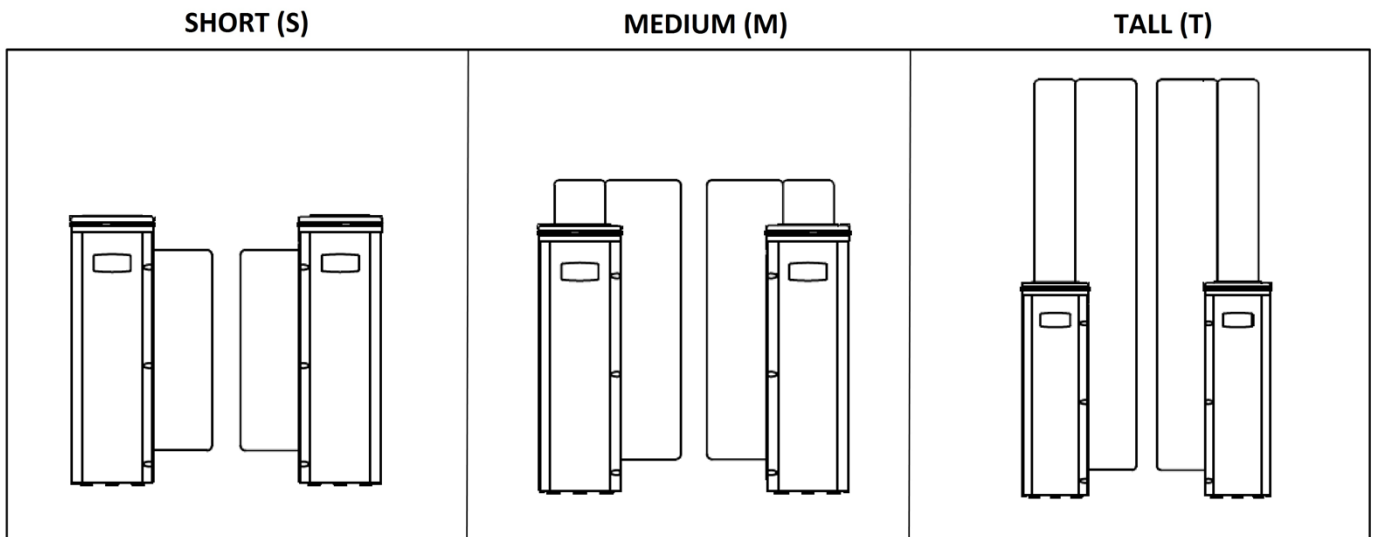

**Design and specifications are subject to change without notice.*

***As the top lid is made of natural granite, it may have variations in color tones and patterns.*

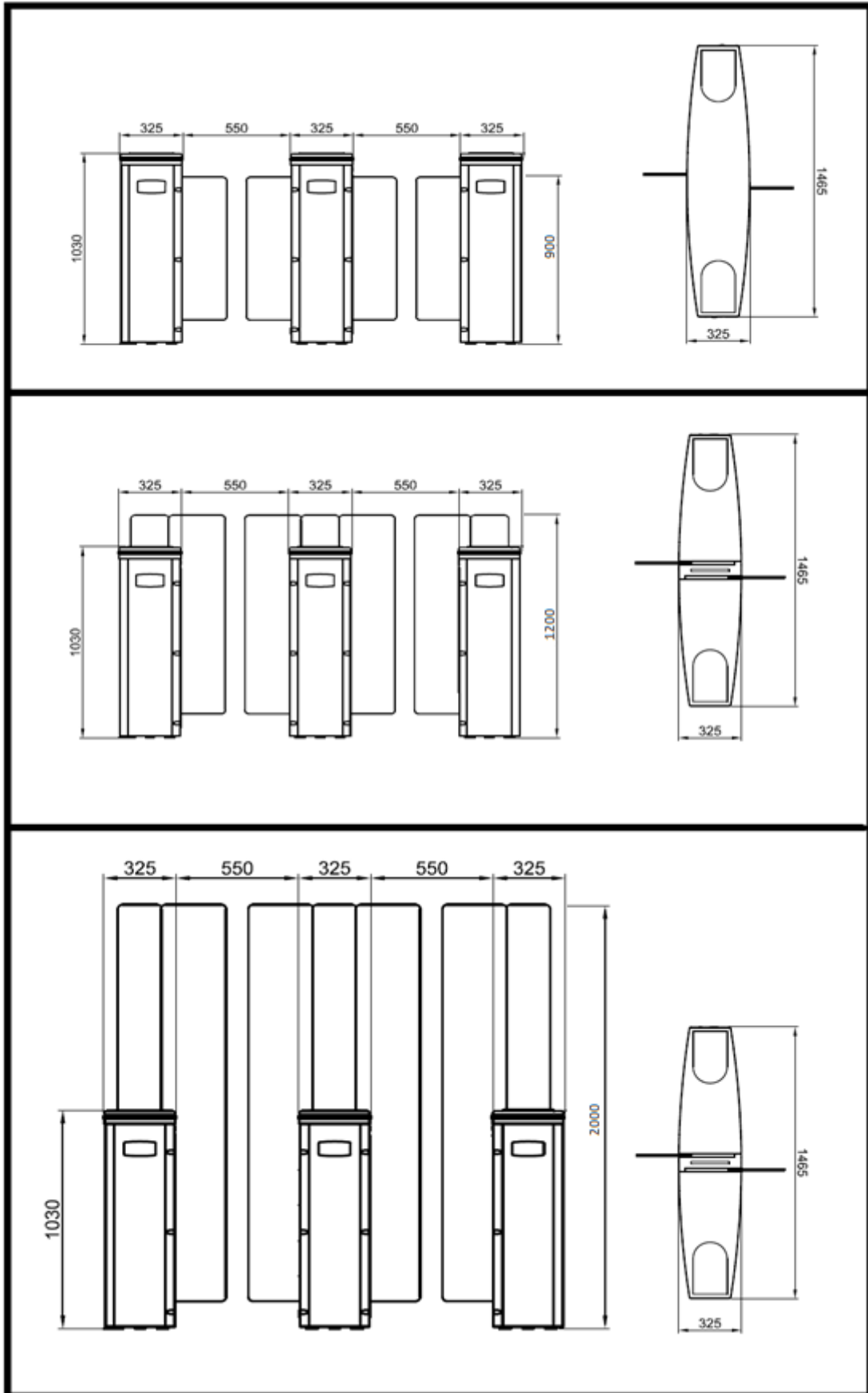

**Design and specifications are subject to change without notice.*