

TECHNICAL SPECIFICATIONS

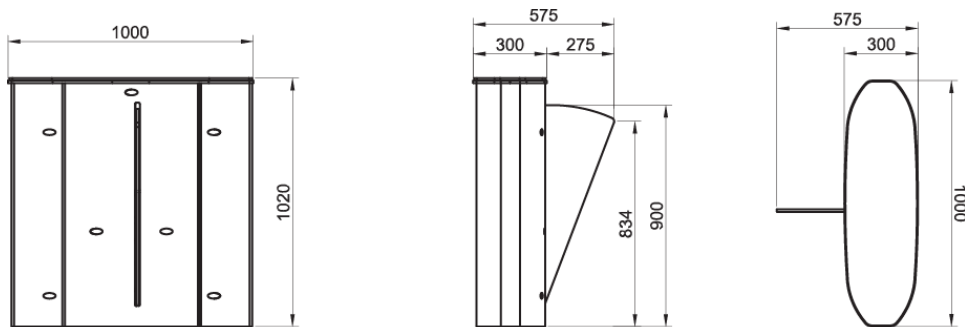

HG 02 GL-S : SINGLE UNIT (LEFT or RIGHT)



HG 02 GL-C : CENTER UNIT

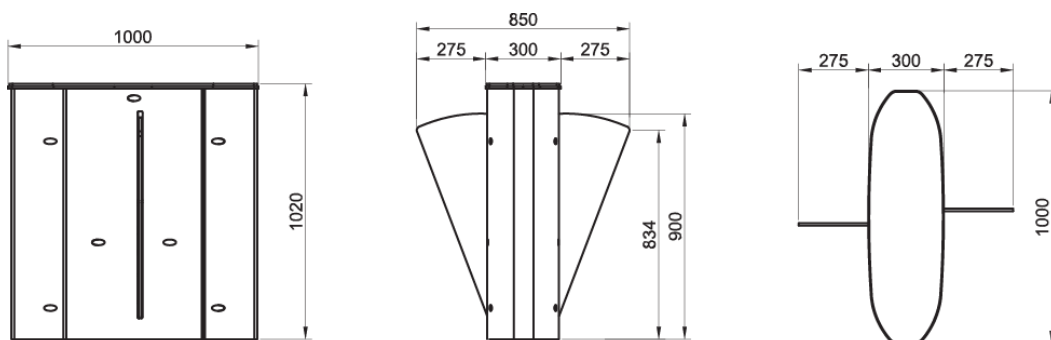

TECHNICAL SPECIFICATIONS

GENERAL SPECIFICATIONS

Power	110/220V. 60/50 Hz. AC (% ± 10), 24 V DC. Single Unit : at stand-by ~10 W, during passage max. ~39 W Center Unit : at stand-by ~10 + 10 W, during passage max.~ 39 + 39 W
Dimensions	Single Unit : 1000 x 1020 x 300 + wing length (275) mm Center Unit : 1000 x 1020 x 300 + wing length (275 x 2) mm
Body Features	The body is made of 304-grade (opt. 316-grade) satin finished stainless steel.
Wings	RGB LED illuminated, 10 mm impact resistant tempered glass (opt. polycarbon) wings.
Top Lid	Tempered glass top lid (opt. other materials).
Weight	~59 kg (single), ~77 kg (center).
Operating Temperature, Humidity, IP Rating	(-20°C) – (+68°C) (opt:- 50°C with heater positive), RH 95% (±2%) non-condensing), IP 44 indoor.

SYSTEM SPECIFICATIONS

Indicators	An illuminated acrylic layer under the glass top lid is included. At standby, the acrylic layer illuminated in blue; during authorised passages it flashes green; when an unauthorized attempt is detected or during alert mode it flashes red. Sliding asteroid animated indicator on top lid is optionally available.
Control System	Controlled by dry contact or grounding input. All inputs are opto-coupler protected.
Integration	Compatible with all access control systems that provide dry contact or grounding outputs. Optional RS232/RS485/TCP IP control module is available.
System Features	Electronically controlled rapid wing movement for quick and smooth bi-directional passages. Internal dip switch selectable free passage by photocell detection, restricted access, controlled access on both or single direction modes are built in features.
Time Out	3-6-9-12 dipswitch selectable.
Output Data	System provides dry contact passage feedback by relays separately for each direction. System provides busy signal during passage.

FUNCTIONAL FEATURES

Passage	System works bi-directional (in-out). Normally the wings are in closed position. Upon authorization from the control unit, the wings open to allow passage of a single person and return to the closed position. In case of multiple authorization from the control unit, wings keep open until the continuous passages are completed. Built in sensors detect unauthorized entry into the passge area and gate generates audio/visual alarm. An unauthorized attempt by entering the passage area before the wings are closed, wings close to prevent the unauthorized passage while the gate generates alarm.
----------------	---

TECHNICAL SPECIFICATIONS

In any case, presence of a person between the open wings is detected by safety sensors and gate stops the movement of the wings to prevent a harm to the person.

Flow Rate

Wing opening speed/time : 0,5 sec. wing closing speed/time: 0,5 sec.
Nominal : ~30 - 60 passages/minute (recommended reference figure).
Utilisation of different access control units can change the flow rate.

Emergency Mode

System allows free passage in emergency mode and in case of power failure by retracting wings into the gate body (powered by internal back-up battery).

CERTIFICATION

Compliance

CE, RoHS

OPTIONAL ACCESSORIES AND APPLICATIONS

Options

Sliding asteroid animated indicator on top lid, remote control unit, manual control, coin slot/intelligent coin system and coin box, counter, card reader pole, photocell alarm sensor, interface unit for PC, RS485, RS232 and LAN, audio-messaging system, -base plate, separator.

Note: A passage lane consists of min. 2 pieces of single units facing each other.

TECHNICAL SPECIFICATIONS

